

FCIA Education – Standards 'L'- Ratings ASTM Movement Standard DRAFT

Eric Keeton, Tracy Smith, Luke Woods

May 2, 2013



Standards – ‘L’ Ratings

714.5 Penetrations in smoke barriers.

Penetrations in smoke barriers shall be protected by an approved through penetration firestop system installed and tested in accordance with the requirements **of UL 1479** for air leakage. The L rating of the system measured at 0.30 inch (7.47 Pa) of water in ***both the ambient temperature and elevated temperature tests, shall not exceed....***

Standards – ‘L’ Ratings

IBC 714.5 Penetrations in smoke barriers.

.....

1. **5.0 cfm per square foot** ($0.025\text{m}^3 / \text{s} \cdot \text{m}^2$) of penetration opening **for each through-penetration firestop system**;

or

2. **A total cumulative leakage of 50 cfm** ($0.024\text{m}^3/\text{s}$) for any **100 square feet (9.3 m²) of wall area, or floor area.**

Standards – ‘L’ Ratings

- *Firestopping & ‘Systems’*
 - ‘L-Ratings’ – 2012 IBC
 - 50cfm 100 sf of wall, per UL 1479
 - < 5cfm/sf opening area, per UL 1479
 - ***Who’s Counting - Systems?***

Standards – ‘L’ Ratings

- *Firestopping & ‘Systems’*
- ***‘Smoke Sealing’....***
- *Is a Firestop Product with ‘L’ Rating Required??*
 - *Smoke Barrier?*
 - *Non Fire Rated Smoke Partition?*

Standards – ‘L’ Ratings

- *Firestopping & ‘Systems’*
- *‘Smoke Sealing’....*
- *Is a Firestop Product with ‘L’ Rating Required??*
 - *Smoke Barrier?*
 - *Non Fire Rated Smoke Partition?*

ASTM DRAFT Standard Movement



March 25, 2009

Mr. Randall Bosscawen
Multicon – Fire Containment
1320 McKinley Avenue
Columbus, OH 43222

RE: Structural Movements

Dear Randy:

This letter will describe the amount of structural movements that occur in buildings and how they relate to fire sealants that close off openings that penetrate through walls and floors. Because of the broad nature of possible movements in the structure, this description will be very general and will only provide approximate guidelines for estimating movements. There are several types of movement that can occur in structures; the most common is the vertical deflection or sag that occurs when a beam is subjected to vertical or gravity loads. Within this category, there are two types of loading: dead loads (the weight of the structure itself and all loads that are a fixed part of the building, interior walls, exterior walls, and fixed equipment), and live loads (vary over the life of the structure, i.e. the weight of occupancy, furniture, stored material, etc.). Of these two types of loads, the one that would be of most interest is live load since it will be the one that will change over time and thus cause movement to occur in the floors and walls through which penetrations occur. If a pipe or duct is attached to a floor structure that deflects over time and it is supported on the ground or off another floor

ASTM DRAFT Standard Movement

- *Why Movement --- KORDA Assoc., SE's*
 - *Penetrating items Move*
 - *Floor and Wall Assemblies Move*
 - *'Vertical or Gravity Loads' – Sag*
 - *'Live Loads'*
 - *Furniture*
 - *Traffic*

ASTM DRAFT Standard Movement

- *Penetrating Items Attached to Floor*
 - *Moving Stored Material (Files, Furniture, etc)*
 - *Fork Lifts*
 - *Heavy Equipment, People*
 - *Cars, Trucks*

ASTM DRAFT Standard Movement

- *Live Loads*
 - *Design – Safely Supporting*
 - *Normal – Routine Daily Use*

ASTM DRAFT Standard Movement

- *Live Loads*
 - *'If Walls are supported on floors that deflect under live loads and the pipes and ducts are supported on floors above, they are not subjected to the same loading simultaneously with the wall supporting the floors'*

ASTM DRAFT Standard Movement

- *Lateral or Horizontal Loading*
 - *Wind, Seismic*
- *Not as much movement expected...as the penetrating items may move with building*
- *Less as approach Column, Support*

ASTM DRAFT Standard Movement

- *Lateral or Horizontal*
- *Thermal Movement*
- *Differential Settlement*

ASTM DRAFT Standard Movement

- *Universal Testing Machine...*
- *Y Direction – Parallel to assembly*
- *Z Direction – Perpendicular to assembly*

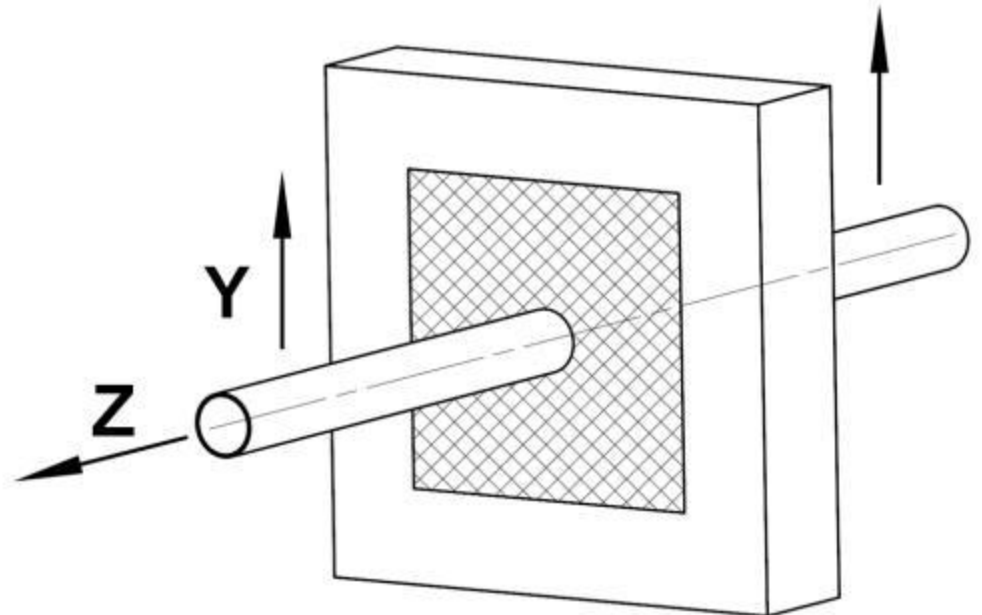

ASTM DRAFT Standard

Movement

4.1 This test method is intended to determine what amplitude of movement a penetration firestop system can be subjected to under standardized test conditions until it is deformed to an extent that its firestopping capabilities become questionable without any additional fire testing or other evaluations. A firestop system capable of accommodating more movement prior to the onset of damage will typically perform better than a firestop system that can accommodate less movement prior to the onset of damage in applications where movement is anticipated. If the amplitude of movement in a design application can be predicted, then the numerical values of measured movement without damage can also be used as one data point in helping to establishing suitability of the firestop system for the given application.

ASTM DRAFT Standard Movement

4.2 This test method will assist users, producers, building officials, code authorities, and others in understanding relative movement capabilities of representative specimens of penetration firestop systems under standardized test conditions.

4.3 This test method is **not intended to reflect** or predict the absolute movement capabilities of all likely permutations of firestop systems under **all likely types of real-life movement.**

ASTM DRAFT Standard

Movement

4.4 This test method does not provide information on:

- 4.4.1 **Durability** of the firestop system under actual service conditions, including the effects of cycled temperature on the firestop system,
- 4.4.2 **Rotational shear** capabilities of the specimen,
- 4.4.3 Any other attributes of the specimen, such as **fire resistance, wear resistance, chemical resistance, air infiltration, water-tightness, and so forth,** and
- 4.4.4 **Compatibility** of firestop system components and the penetrating items.

ASTM DRAFT Standard Movement

4.6 This is not a fire test standard. This test is not be construed as providing a guarantee that a firestop system actually installed in the field will perform as well after movements deemed acceptable per this standard as compared to the same firestop system without any movement.

The only method to determine the impact on the fire resistance rating from any degree of penetrating item movement would be via a fire test in full compliance with ASTM E814.

ASTM DRAFT Standard Movement

- *Testing....*
 - *Sealants – Penetrating Item Centered*
 - *Preformed Device – Hole any shape*
 - *Pipe Bundles – Centered*
 - *Cable, Cable Bundles – substitute a pipe or tube, same material as jacketing or stiffen cables*
 - *Cable Tray – single layer cables, fix to tray*
 - *Ducts – Min. 4” round, 4” x 4” sq.*
 - *Insulated Pipe – bond pipe, insulation*

ASTM DRAFT Standard Movement

- *Laboratory Conditions –*
 - $73^{\circ} F, +(-) 3^{\circ} F$
 - $23^{\circ} C, + (-) 2^{\circ} C$

ASTM DRAFT Standard Movement

- *Cycle Time –*
 - *No > 15 seconds*
 - *No < 5 seconds*
 - *2 sec down, hold 1 sec, 2 sec back to zero,.*
 - *Pause up to 5 minutes....*
 - *Evaluate for Damage....*

ASTM DRAFT Standard Movement

- *Damage*
 - *None*
 - *Small gap or crack...measure*
 - *Large opening*
 - *Deformation*
 - *Total Damage*

ASTM DRAFT Standard Movement

- *Total Damage*
 - *'Obvious function is compromised & ineffective'*
 - *Report 'Allowable Movement'*

ASTM DRAFT Standard Movement

- *Non Intumescent*
 - *Displacement @ detachment from substrate or penetrating item*
 - *Unless not adhered to start*

ASTM DRAFT Standard Movement

- *Failure...*
 - *Intumescent Material*
 - *10% of material moved outside of surface plane of substrate outer faces...upon return to zero position*
 - *Floors - 10% moves above where installed*

ASTM DRAFT Standard Movement

- *If not on both sides of wall...underside of floor*
 - *Gap exists @ zero position*
 - *Shine 100 watt lamp, 12" to specimen.*
 - *Observe light, failure*

ASTM DRAFT Standard Movement

“Damage is here defined as the significantly reduced probability that a firestop system would perform its intended function of preventing the spread of fire and products of combustion”

ASTM DRAFT Standard Movement

“The objective of this ASTM standard test method is to provide a repeatable, easy –to-perform test method that would allow a relative evaluation of the ability of different types of firestop systems to accommodate movement without damage. This standard is written to closely parallel the approach taken in ASTM E1399, which is currently used to evaluate the ability of joint systems, including fire resistance-rated joint systems, to be tested for ability to accommodate movement. “

ASTM DRAFT Standard Movement

“X.2.2 Ultimate responsibility for applying the results of this test method to true - life installations rests with the user of the test

Data. If the user of the test data has reason to believe that the extension of data principles presented here would not hold true for a given

situation, the methods should not be used.” X.2.3

If applicable, verify with the Authority Having Jurisdiction regarding th

e acceptability

of using data obtained from this test method to make decisions pertaining to field installations that require Approval.

ASTM DRAFT Standard Movement

“X.2.3 If applicable, verify with the Authority Having Jurisdiction regarding the acceptability of using data obtained from this test method to make decisions pertaining to field installations that require Approval.”

ASTM DRAFT Standard Movement

- *What's this mean to FCIA Members ?*
 - *Standard not approved yet..*
 - *Annular Space Sizes will have minimums*
 - *Movement data needed*
 - *Mechanical Engineers*
 - *Structural Engineers*

ASTM DRAFT Standard Movement

- *What's this mean to FCIA Members ?*

FCIA Education – Standards 'L- Ratings Movement DRAFT

Eric Keeton, Tracy Smith, Luke Woods

May 2, 2013

