

Fire, Smoke, and Combination Fire Smoke Dampers



Agenda

- ▶ **Installation/Configuration**
 - Fire Dampers
 - Smoke Dampers
 - Combination Fire/Smoke Dampers
- ▶ **Operational Test/Inspection**
- ▶ **Periodic Test/Maintenance**



Damper Selection

- **Comply with code requirements**
- **Design for long term use**
- **Modification restrictions**



What makes an approved system?

- ▶ **Barrier**
- ▶ **Product**
- ▶ **Installation**

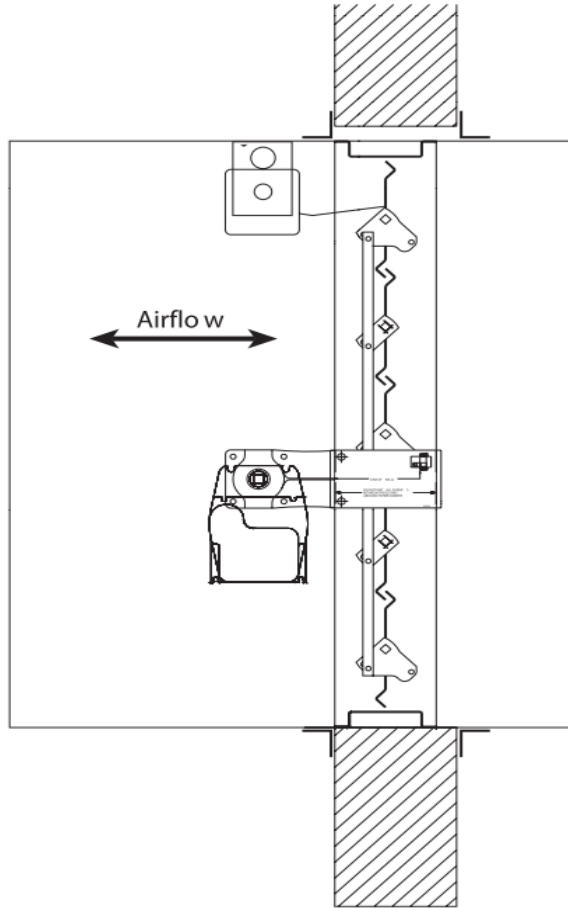

Barrier First – I503



What is it?

► Labels



Is it right?

UL | Online Certifications Directory - Search Results - Microsoft Internet Explorer

Address: http://database.ul.com/cgi-bin/XYV/cgfind.new/LISEXT/1FRAME/srchres.html?collection=/data3/venty_collections/lisext&dkhome=/data3/venty_sw_rev2<

Underwriters Laboratories Inc.

Number of hits: 39

Previous Page

Refine Your Search · Home

Company Name	Category Name	Link to File
ACME ENGINEERING & MFG CORP	Dampers for Fire Barrier and Smoke Applications	EMME.R16596
ACTION AIR USA, DIV OF TOMKINS	Dampers for Fire Barrier and Smoke Applications	EMME.R16693
AIR BALANCE INC	Dampers for Fire Barrier and Smoke Applications	EMME.R4708
AMERICAN WARMING & VENTILATING	Dampers for Fire Barrier and Smoke Applications	EMME.R16398
ARLAN DAMPER CORP	Dampers for Fire Barrier and Smoke Applications	EMME.R8610
ARROW UNITED INDUSTRIES, DIV OF MESTEK	Dampers for Fire Barrier and Smoke Applications	EMME.R19235
BUCKLEY ASSOCIATES INC	Dampers for Fire Barrier and Smoke Applications	EMME.R9491
C&S AIR PRODUCTS	Dampers for Fire Barrier and Smoke Applications	EMME.R14981
CESCO PRODUCTS	Dampers for Fire Barrier and Smoke Applications	EMME.R6462
GREENHECK FAN CORP	Dampers for Fire Barrier and Smoke Applications	EMME.R13317
GULF MECHANICAL ACOUSTIC MFG CO	Dampers for Fire Barrier and Smoke Applications	EMME.R20671
HART & COOLEY INC	Dampers for Fire Barrier and Smoke Applications	EMME.R16751
HERCULES INDUSTRIES INC	Dampers for Fire Barrier and Smoke Applications	EMME.R9356

start | Microsoft ... | Microsoft Exce... | CAPS | Out | Microsoft Pow... | UL | Online Ce... | 2:37 PM

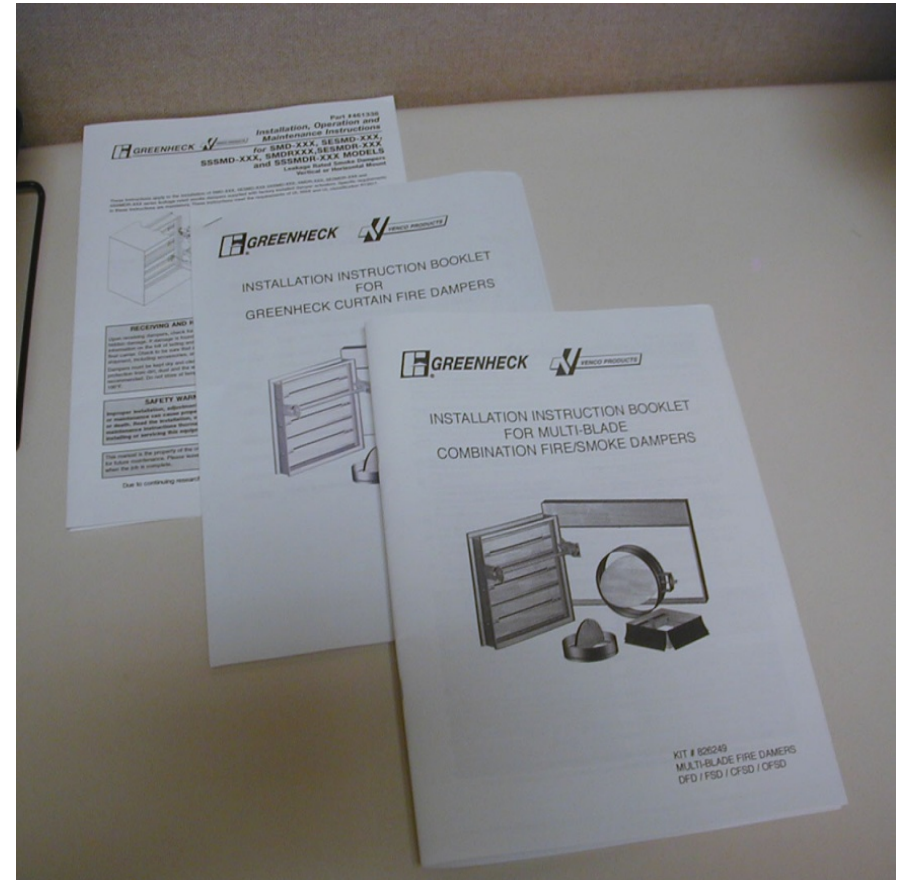

UL 555: Fire Dampers

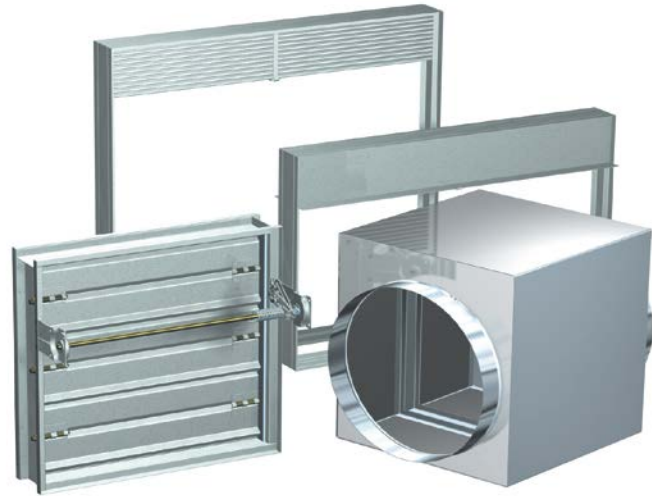

UL 555 Classifications

▶ Static

- For use in HVAC systems that shut off in case of a fire emergency.



▶ Dynamic

- For use in HVAC systems that continue running during a fire emergency.
- Dynamic airflow test
- Increments of 1000 fpm



Damper Construction

▶ Type

- Curtain
- Multi-blade
 - Blade Type

▶ Material

- Galvanized
- 304 stainless steel
- 316 stainless steel

▶ Mounting

- Vertical
- Horizontal



Damper Ratings

- ▶ **Closure Temperature**
 - 165° F (160 minimum per IBC)
 - 350° F (maximum per IBC)
- ▶ **Operational Temperature**
 - 250° F (minimum)
 - 100° F increments

Damper Ratings

▶ **Operational Airflow Rating**

- 2000 fpm
- 3000 fpm
- 4000 fpm
- +

▶ **Operational Closure Pressure Rating**

- 4 in. wg.
- 6 in. wg.
- 8 in. wg.
- +

Combination Fire Smoke & Fire Dampers - Ratings

▶ IBC

- 717.3.2.1 Fire Protection rating. Fire dampers shall have the minimum fire protection rating specified in table for the type of penetration.

Type of Penetration	Minimum Damper Rating (hours)
Less than 3-hour fire resistance rated assemblies	1.5
3-hour or greater fire resistance rated assemblies	3



Fire Damper Selection

▶ System Requirements

- Dynamic vs Static
- Temperature
- Velocity/Pressure
- Size
- Mounting



Mounting

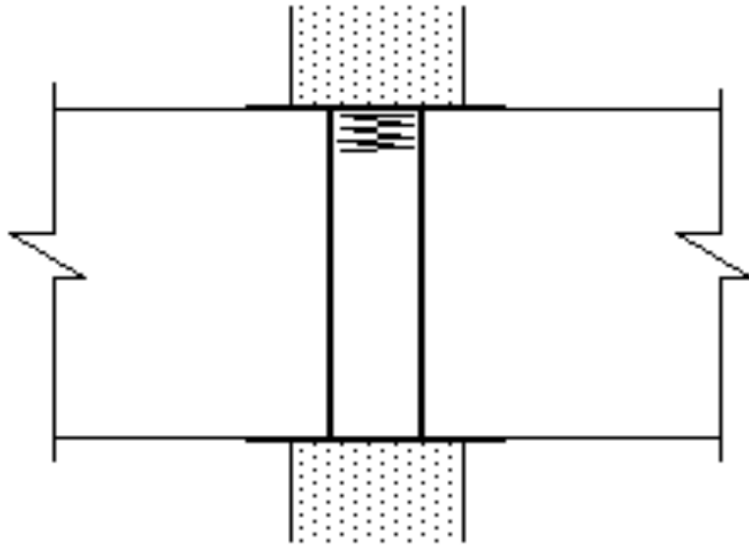

Vertical

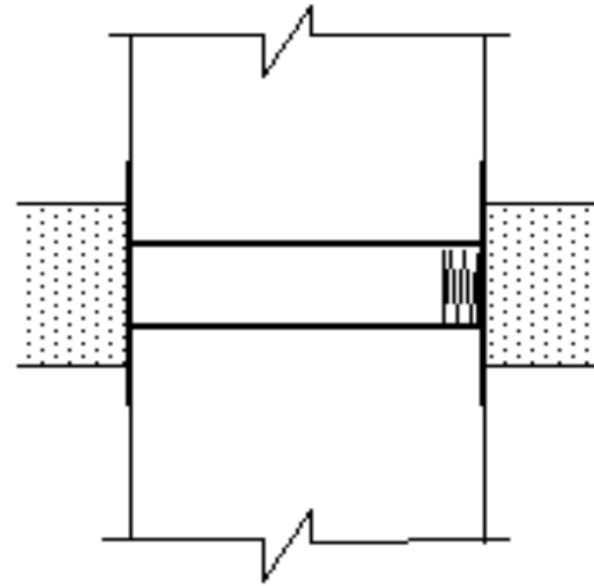

Horizontal

Horizontal Fire or Fire Smoke Damper

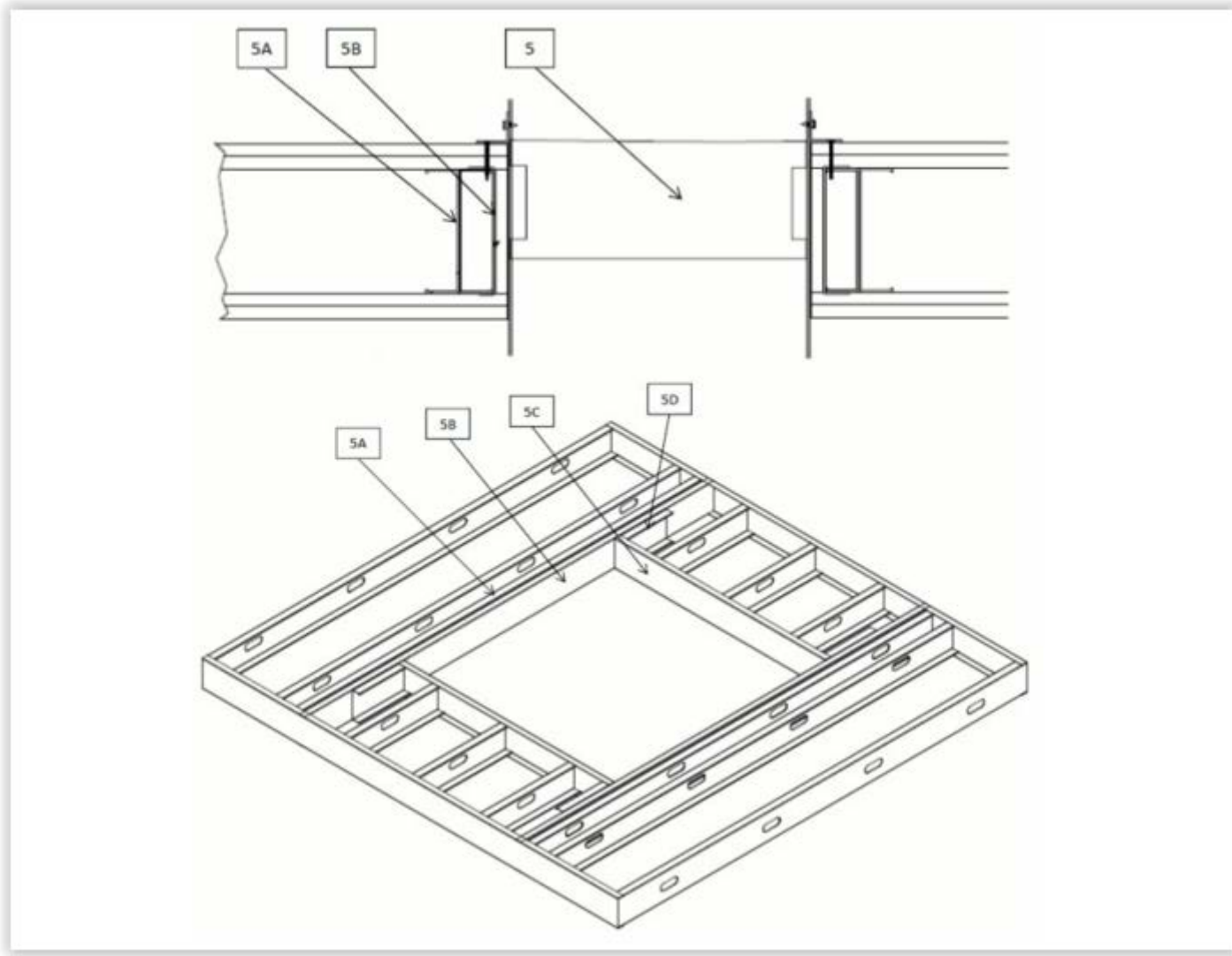

Fire Damper Selection

▶ Performance

- Closure Device
- Controls
- Free Area
- Pressure Loss

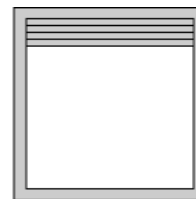

Type A
Blades In Airstream

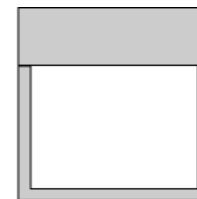

Type B
Blades Out Of Airstream

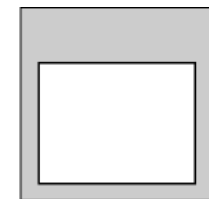

Type C
100% Free Area

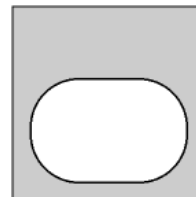

Type CO
100% Free Area

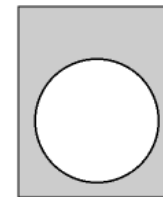

Type CR
100% Free Area

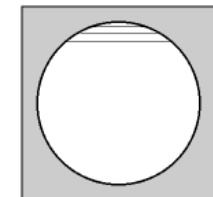

Type R
High Free Area

Transitions

Type R and O
factory furnished
duct collars qualify
as breakaway
connections.

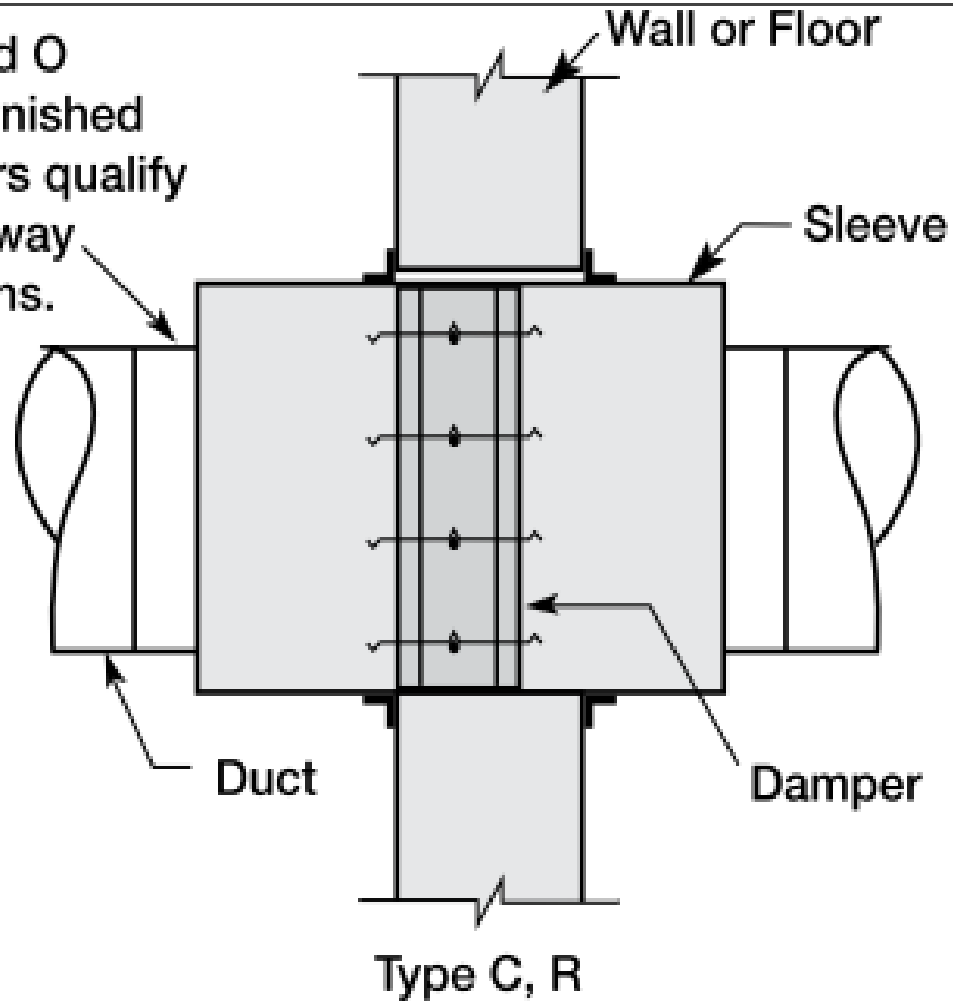

Installation Requirements

Fire and Fire Smoke Dampers

Framing of Opening

- Vertical studs must run floor to ceiling
- Double vertical studs over 36" x 36"
- Wood studs must be covered with sheet rock
- Steel studs do not need to be covered with sheet rock

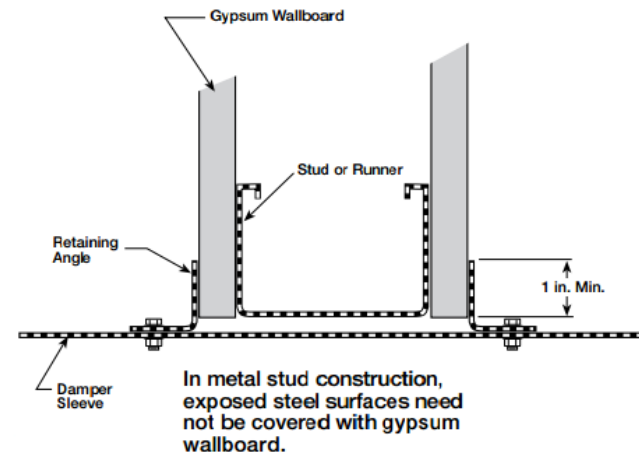
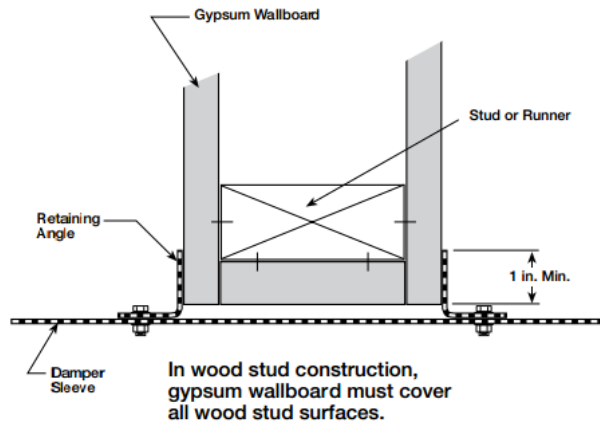
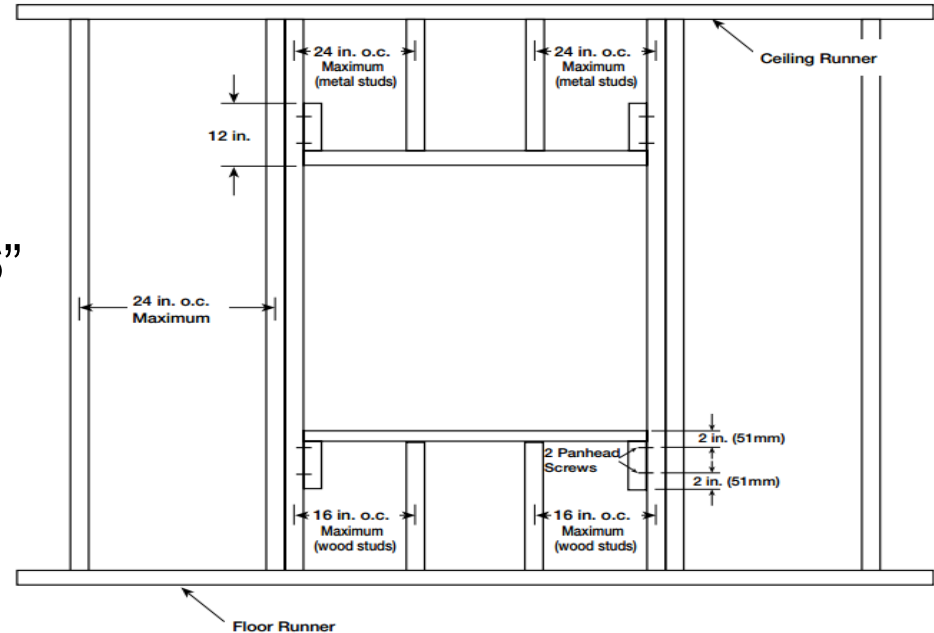

Fire Damper Installation

► Installed with sleeves

- factory or field mounted
- sleeve requirements

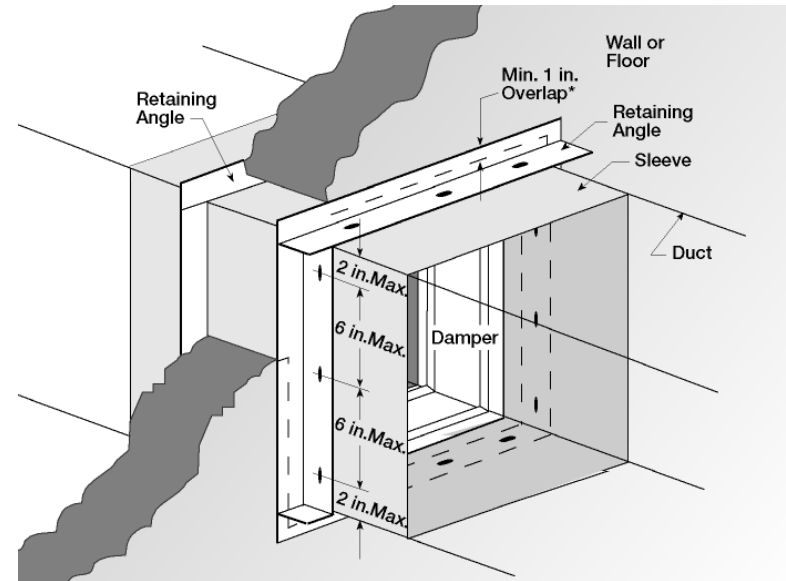

Installation Requirements

Fire and Fire Smoke Dampers

Traditional Installation

1. The centerline of the damper frame must be in the plane of the wall/floor
2. Annular Space Requirements

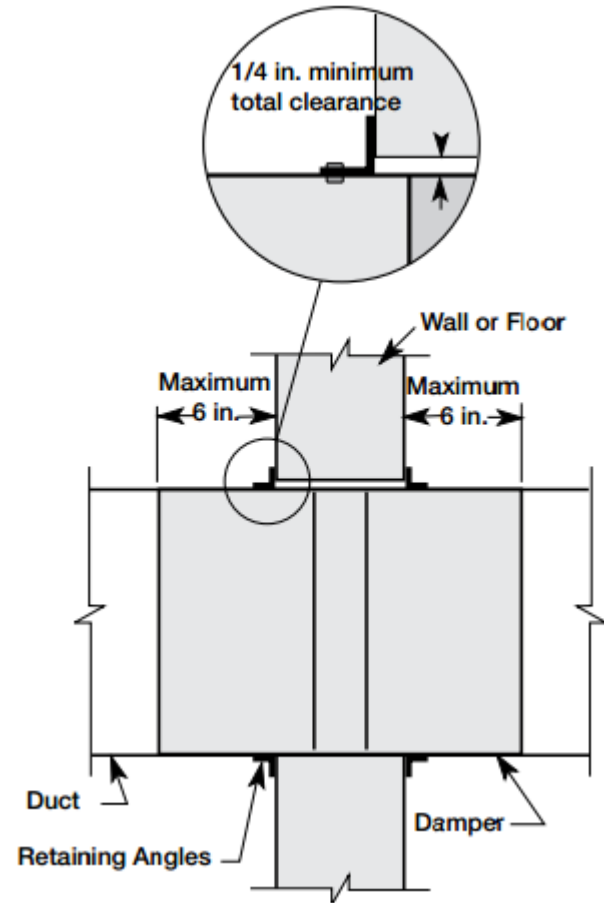

Installation Requirements

Fire and Fire Smoke Dampers

Traditional Installation

3. Retaining Angle Installation

- Angles must be fastened to the sleeve (not to the barrier)
- Attachments 2" from corners then 6" O.C.
- Angles must overlap barrier by at least 1"
- Angles are continuous with no gaps

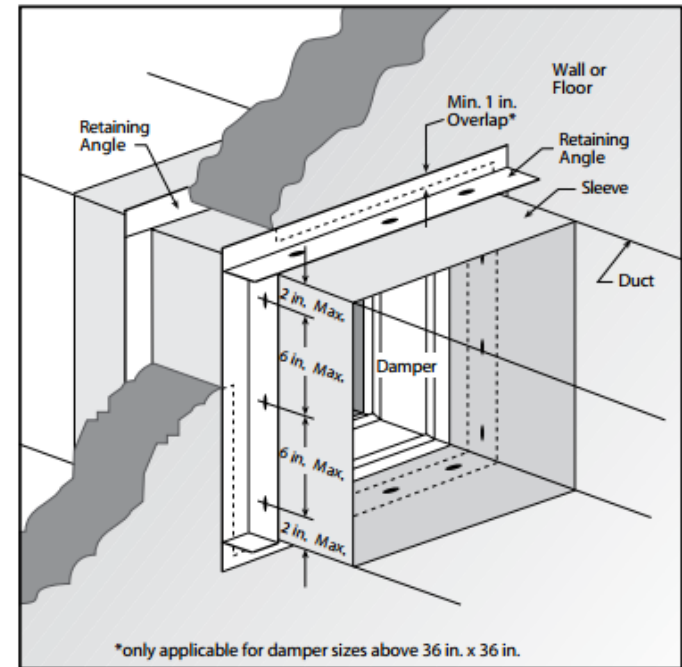

Installation Requirements

Fire and Fire Smoke Dampers

Alternate Installation

1. Single Side Angle
2. 3 Sided Angle

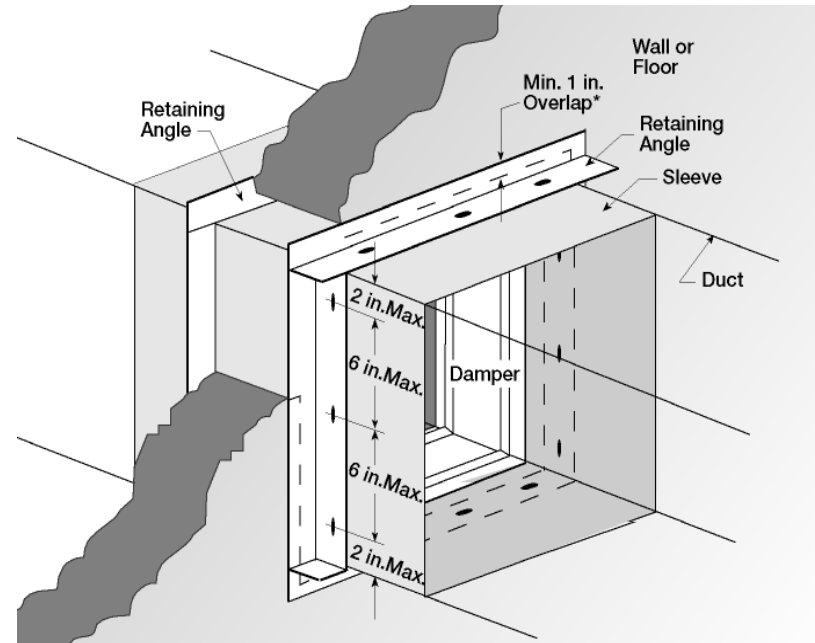
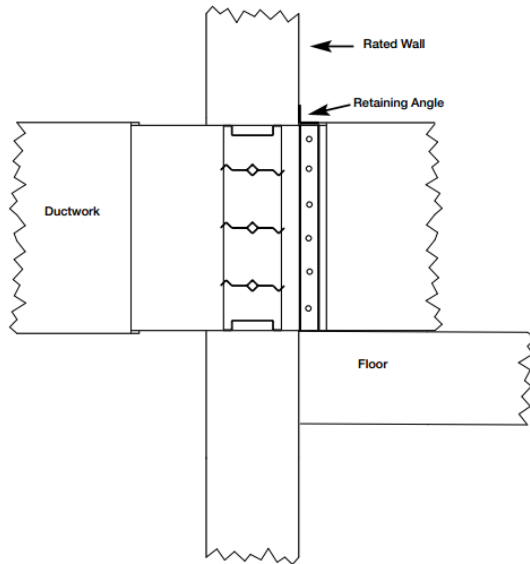

Installation Requirements

Fire and Fire Smoke Dampers

Out-Of-Wall Installations

Commonly used in shaft walls installations where there is no external access to the actuator.

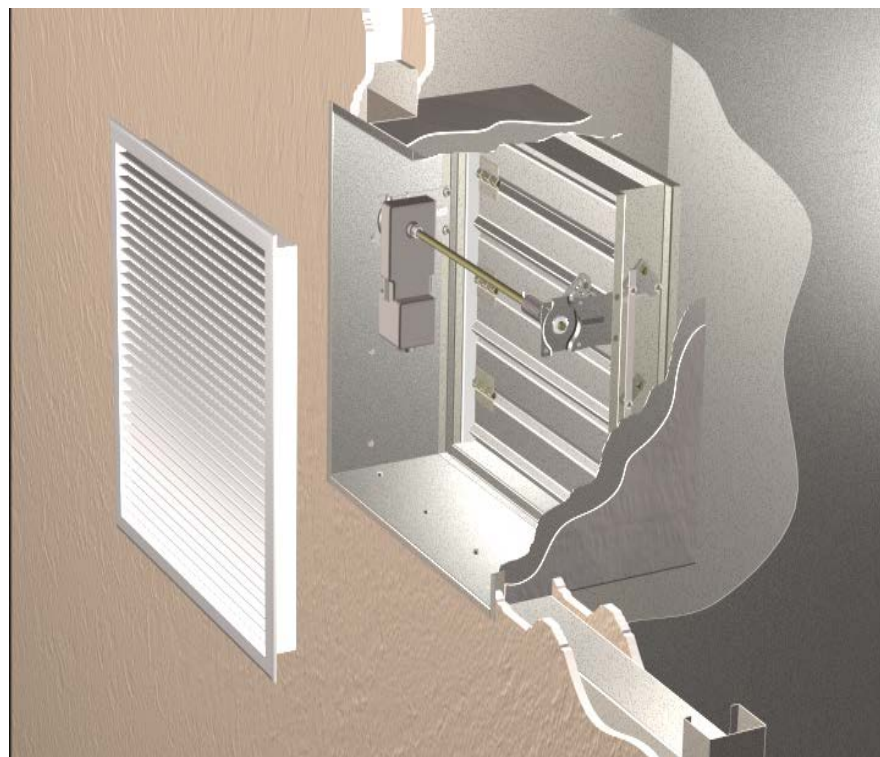
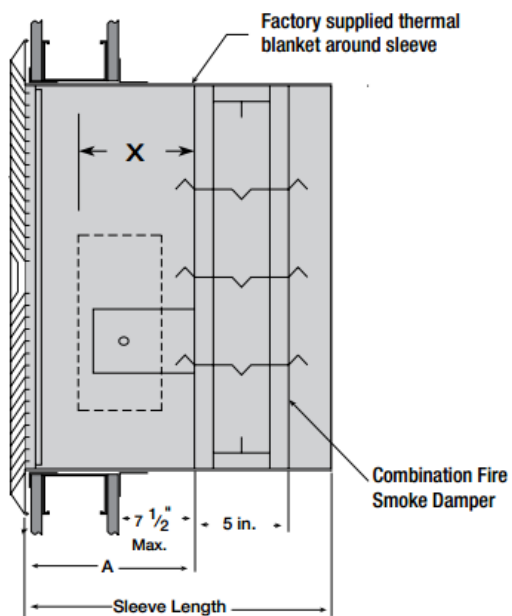

Out-of-Wall Fire and Fire Smoke Dampers



Out-of-Wall Fire and Fire Smoke Dampers



Over-Sized Opening

- ▶ **Objective** - Protect a 160 x 94 ventilation penetration in a 2 hr rated barrier
- ▶ **Challenge** - The largest tested and listed damper system in the world for this application is 144 x 96
- ▶ **Solution** -



Over-Sized Opening

▶ Static

- For use in HVAC systems that shut off in case of a fire emergency.

▶ Solution(s)

- Make smaller openings
- ▶ Same construction as barrier
- ▶ Mullion

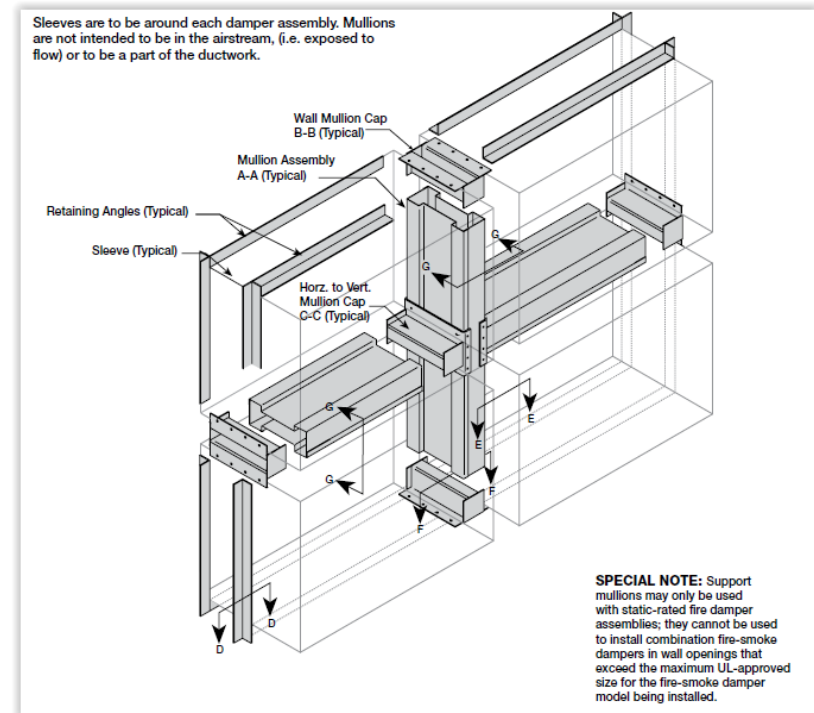

These installation instructions apply to the fabrication and construction of generic support mullions. Support mullions are necessary whenever static fire dampers are installed into a vertical opening that is larger than the largest UL rated size for that damper. The mullions allow construction of a fire barrier that is larger than the maximum available size.

Sleeves are to be around each damper assembly. Mullions are not intended to be in the airstream, (i.e. exposed to flow) or to be a part of the ductwork.

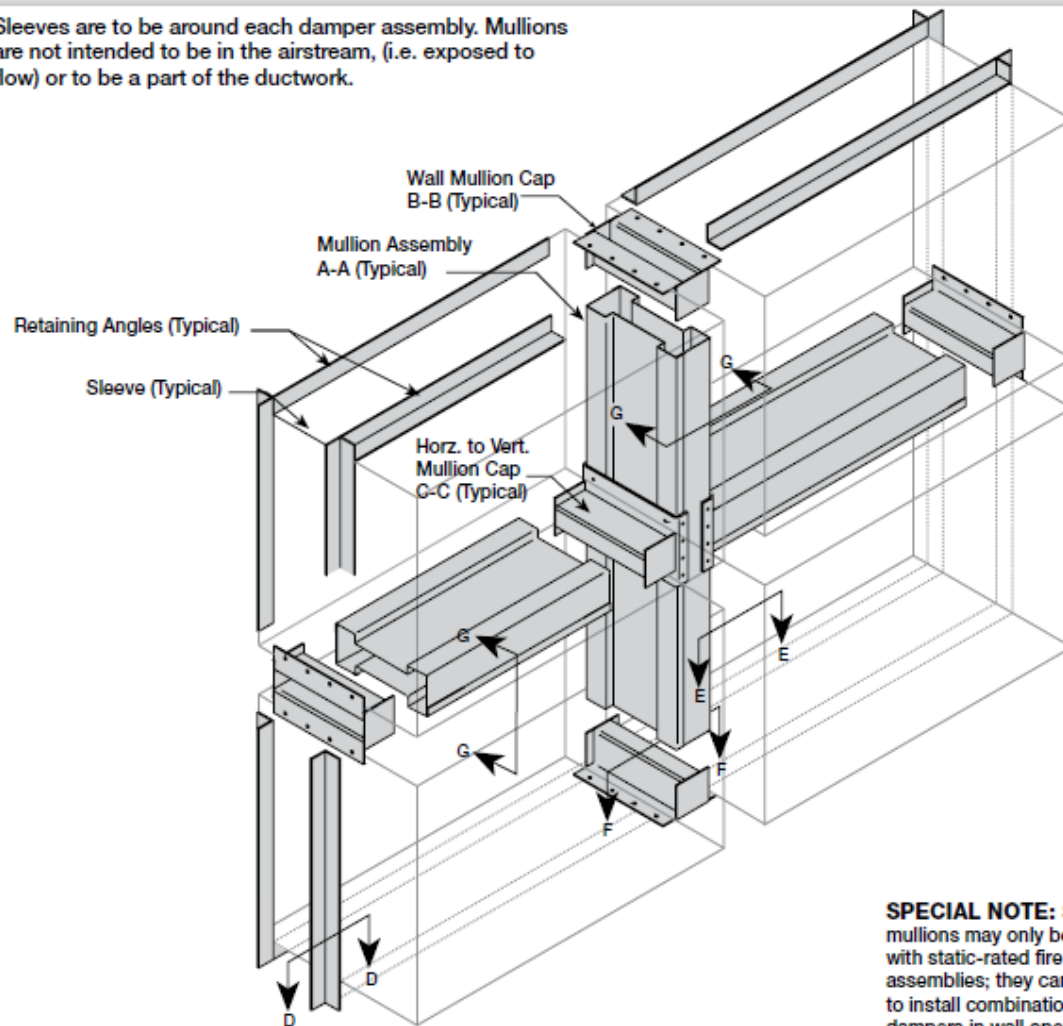

SPECIAL NOTE: Support mullions may only be used with static-rated fire damper assemblies; they cannot be used to install combination fire-smoke dampers in wall openings that exceed the maximum UL-approved size for the fire-smoke damper model being installed.

Over-Sized Opening

▶ Static

- For use in HVAC systems that shut off in case of a fire emergency.

▶ Solution(s)

- Make smaller openings
- ▶ Same construction as barrier
- ▶ Mullion
- ▶ AHJ Approved

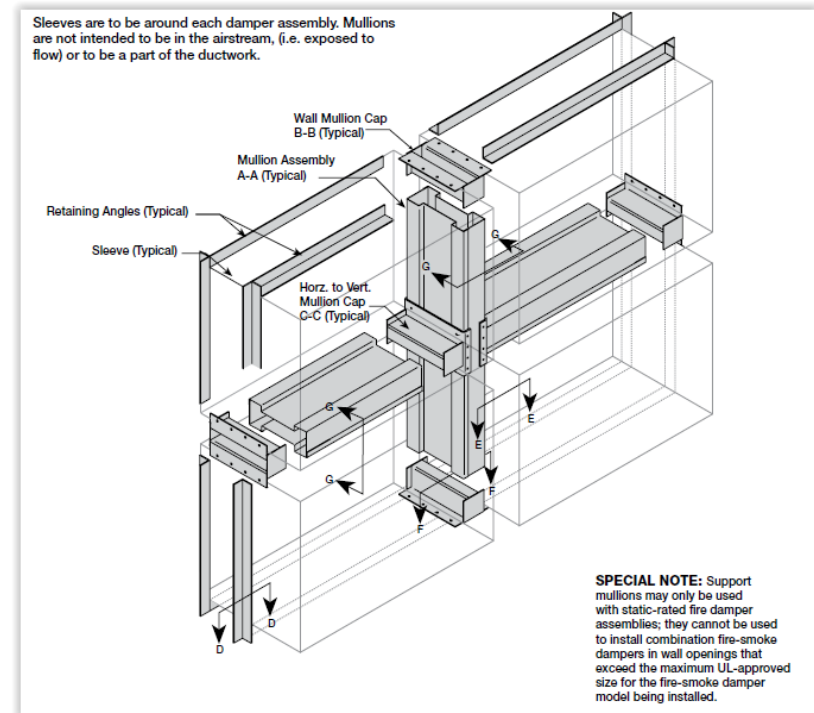

Over-Sized Opening

▶ **Dynamic**

- For use in HVAC systems that continue running during a fire emergency.
- Dynamic airflow test
- Increments of 1000 fpm

▶ **Solution(s)**

- Much harder

- ▶ *Cannot exceed the velocity rating of the tested and listed system*

2,000 FPM (23 MPH)

Sleeves are to be around each damper assembly. Mullions are not intended to be in the airstream, (i.e. exposed to flow) or to be a part of the ductwork.

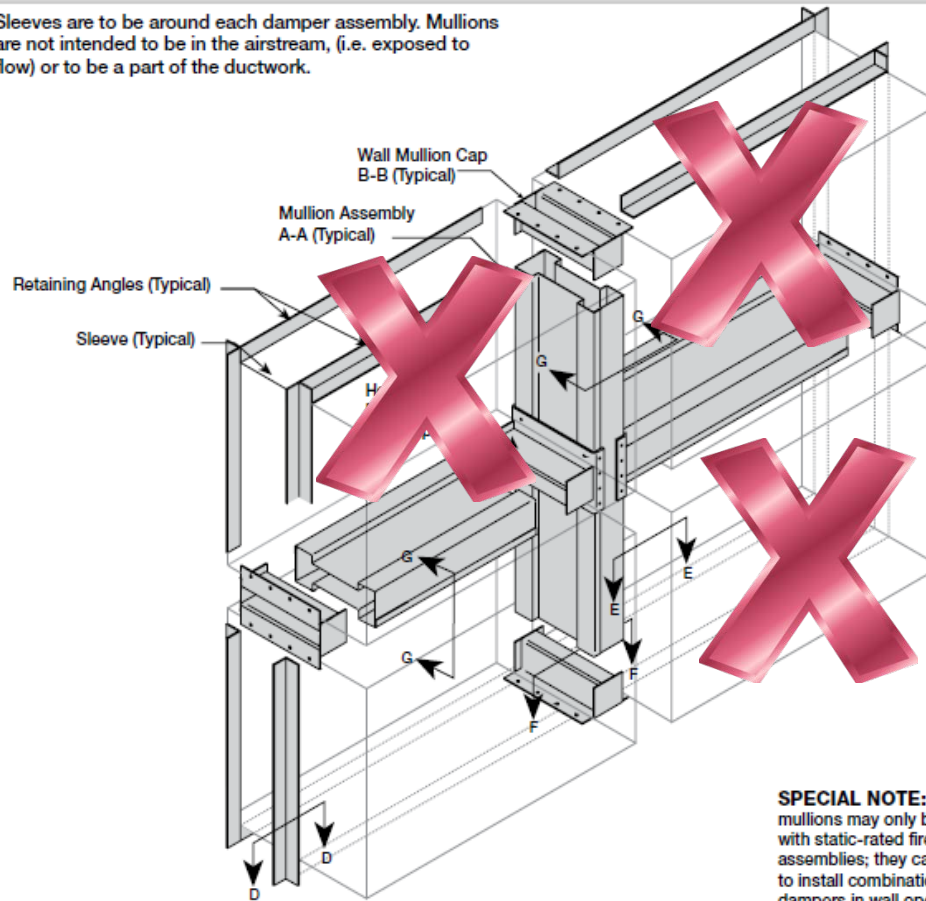

SPECIAL NOTE: Support mullions may only be used with static-rated fire damper assemblies; they cannot be used to install combination fire-smoke dampers in wall openings that exceed the maximum UL-approved size for the fire-smoke damper model being installed.

8,000 FPM (92 MPH)

Installation Requirements

Fire and Fire Smoke Dampers

Traditional Installation

4. Duct to Sleeve Connections

- Transverse Joints
- TDC/TDF
- Manufactured Systems
- Rigid Connection (when allowed)

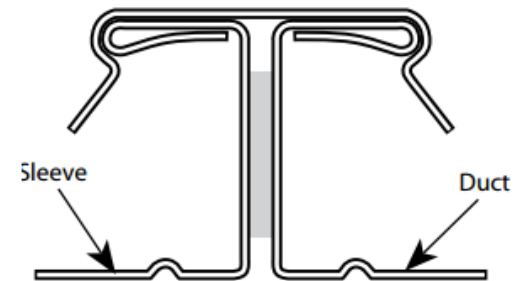
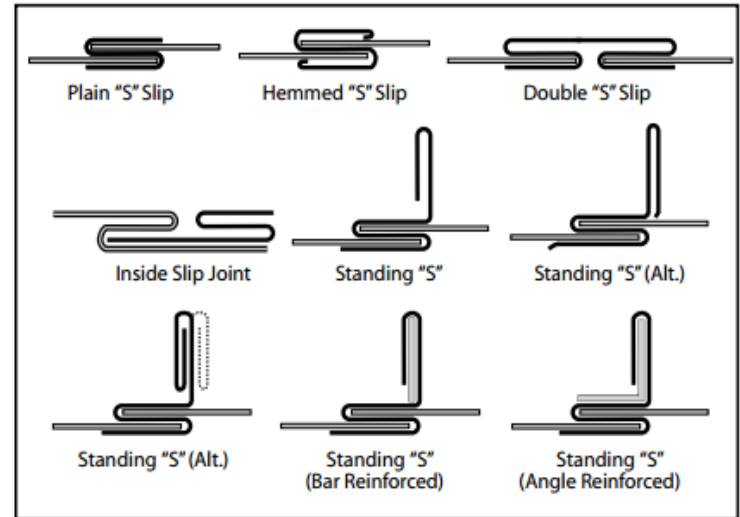
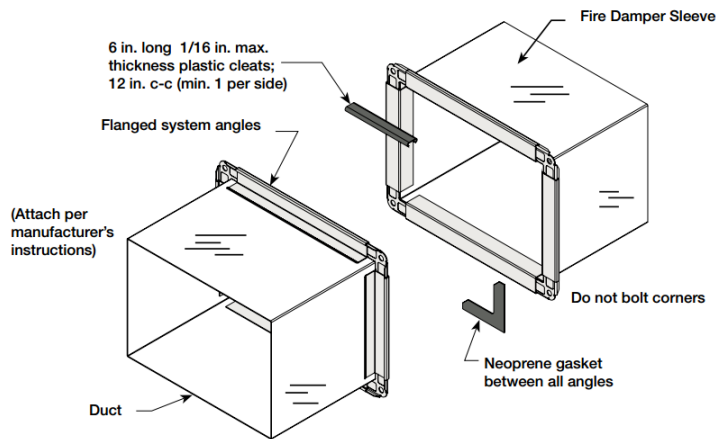

Typical TDC/TDF joint

Greenheck Connect-All Breakaway Test

Installation Requirements

Access and Identification

Section 716.4 of the IBC

- *Fire and smoke dampers shall be provided with an approved means of access, which is large enough to permit inspection and maintenance of the damper and its operating parts.*
- *Access points shall be permanently identified on the exterior by a label having letters not less than ½” in height reading: Fire/Smoke Damper, Smoke Damper or Fire Damper.*



UL 555S: Smoke Dampers



Smoke Damper Construction

▶ Type

- multi-blade
- 3-V or airfoil blade

▶ Construction

- blade and jamb seals
- *always* with a UL-approved actuator



Smoke Damper Actuators

▶ Mounting

- must be factory mounted
- internal or external

▶ Operation

- spring return
- two position or modulating



UL 555S Classifications

▶ Leakage Class

- I (8 cfm/sq. ft @ 4 in.wg)
- II (20 cfm/sq. ft @ 4 in.wg)
- III (80 cfm/sq. ft @ 4 in.wg)

▶ IBC 716.3.2

- Smoke damper leakage ratings shall not be less than Class II.

▶ Operational Temperature

- Maximum operating temperature for damper
- 250° F
- 350° F

Amount of Time to Fill a Room with Smoke Based on Leakage Class

Leakage Class	Length of Time
I	= 100 minutes
II	= 40 minutes
III	= 10 minutes

24"x 24"
(610mm x 610mm)
Damper

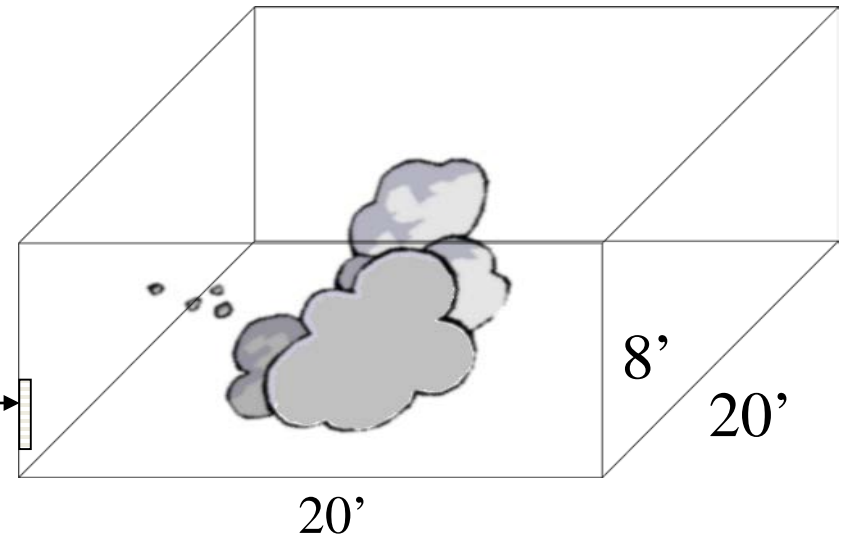

Smoke Damper Installation

- ▶ **Installed in ductwork**
 - with sleeve
 - without sleeve
- ▶ **Location**
 - Centerline within 24" of the barrier

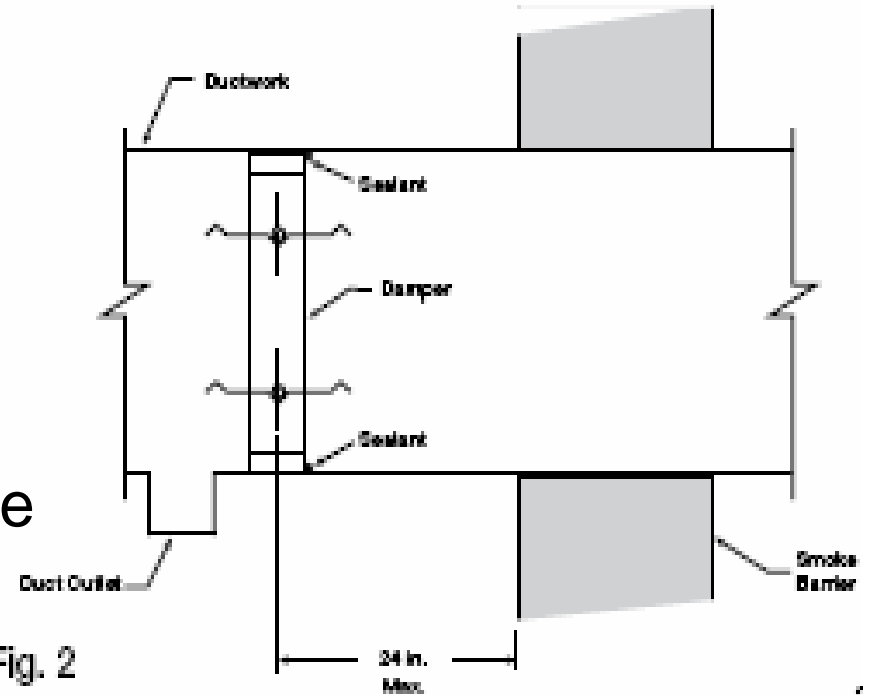

Smoke Damper Installation

- ▶ **In Accordance with Manufacturer's IOMs**
- ▶ **Sealing Damper**
 - It is acceptable to seal damper frame and duct with approved sealants.
- ▶ **Actuator Requirements**
 - Wire actuator in compliance with local wiring codes.
 - Refer to wiring diagrams for each actuator.

Combination Fire/Smoke Dampers

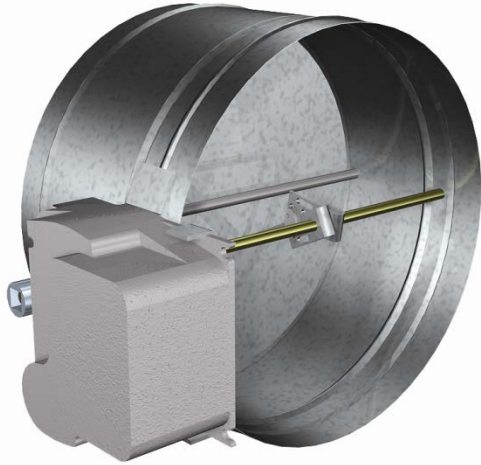

Purpose of Fire/Smoke Damper

- ▶ Provide the same level of protection as individual fire and smoke dampers.
- ▶ Installation guidelines of fire and smoke dampers apply.



Fire Smoke Installation

▶ Actuators

- UL-certified actuators
- installed at factory

▶ Operation

- spring return
- two position or modulating



Fire/Smoke Damper Closure Devices

- ▶ **Fuse Link**
- ▶ **Electronic Link**
 - bi-metallic sensor
 - wired in series with actuator
 - cuts power to actuator when temperature is reached
 - resettable

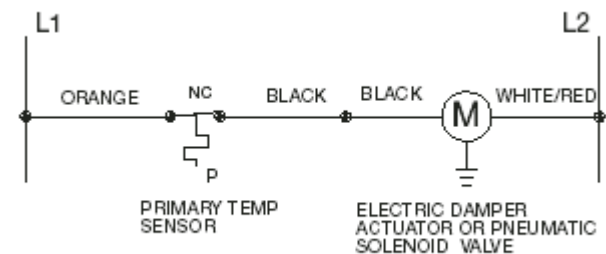

Operational Test/Inspection

Importance of Inspection



Damper installed racked.

Importance of Inspection



Misaligned jackshaft on damper.

Importance of Inspection



Actuator in the barrier.

Importance of Inspection



Operational Test

NFPA 80

Standard for Fire Doors and Other Opening Protectives

Frequency

“After the installation of a damper is completed, an operational test shall be conducted.”

Test Method

“The damper shall fully close from the open position.”

“The operational test shall verify that there is full and unobstructed access to the fire damper and all listed components.”

“All indicating devices shall be verified to work and report to the intended location.”

“The operational test shall be conducted under non-fire HVAC airflow conditions as well as static flow conditions.”



Operational Test

NFPA 105

Standard for the Installation of Smoke Door Assemblies and Other Opening Protectives

Frequency

“An operational test shall be conducted after the building’s HVAC system has been balanced.”

Test Method

“The operational test shall be conducted under normal HVAC airflow conditions as well as static flow conditions. The damper shall fully close/seal under both test conditions.”

“All indicating devices shall be verified to work properly and report to the intended location.”

“Combination fire/smoke dampers shall also meet the testing requirements contained in NFPA 80.”



Notification Options

Position Indication



On-Blade

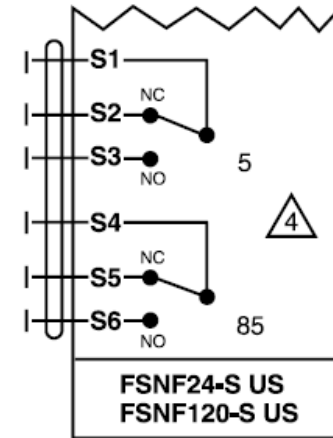

Built-In to Actuator

Period Tests/Maintenance

Importance of Maintenance

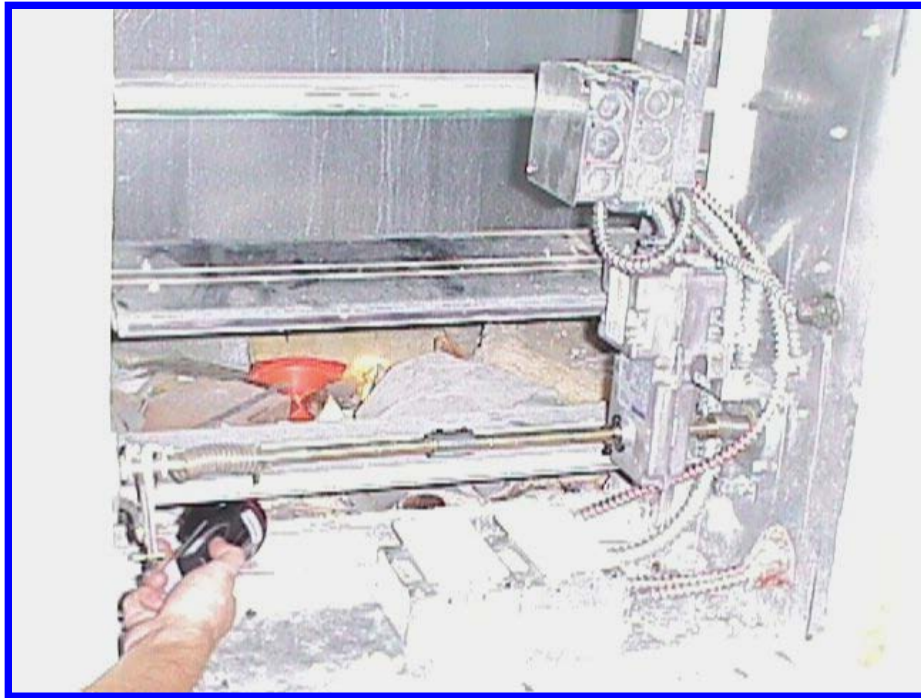

Garbage placed inside of damper.

Periodic Testing Requirements

International Fire Code (IFC)

Smoke Dampers

“All openings protected with approved smoke barrier doors or smoke dampers shall be maintained in accordance with NFPA 105.”

Fire Dampers

“All openings protected with approved doors or fire dampers shall be maintained in accordance with NFPA 80”.

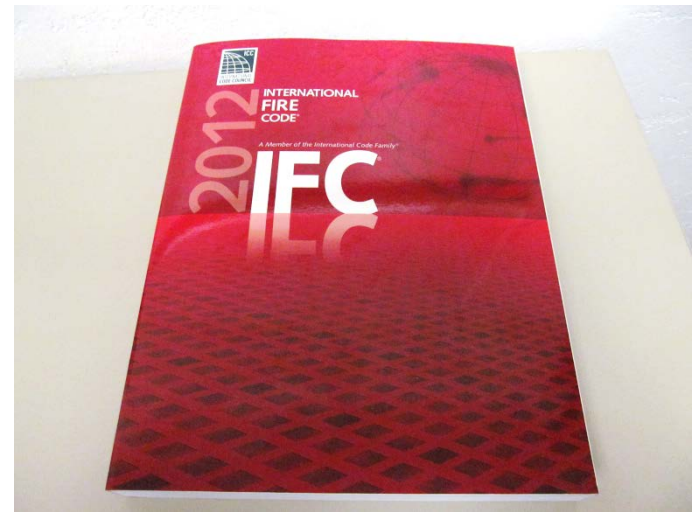

Periodic Testing Requirements

NFPA 80

Standard for Fire Doors and Other Opening Protectives

Frequency

“Each damper shall be tested and inspected 1 year after installation” and then “every 4 years, except in hospitals, where the frequency shall be every 6 years.”

Test Method

“If the fire damper is equipped with a fusible link, the link shall be removed for testing to ensure full closure.”

“The operational test of the damper shall verify that there is no damper interference due to rusted, bent, misaligned, or damaged frame or blades.”



Periodic Testing Requirements

NFPA 80

Standard for Fire Doors and Other Opening Protectives

Maintenance

“All exposed moving parts of the damper shall be dry lubricated as required by the manufacturer”

“If the damper is not operable, repairs shall begin without delay”

“Following any repairs, the damper shall be test for operation in accordance with Section 19.4(Inspection and Testing)



Periodic Testing Requirements

NFPA 105

Standard for the Installation of Smoke Door Assemblies and Other Opening Protectives

Frequency

“Each damper shall be tested and inspected 1 year after installation” and then “every 4 years, except in hospitals, where the frequency shall be every 6 years.”

Test Method

“If the fire damper is equipped with a fusible link, the link shall be removed for testing to ensure full closure.”

“The operational test of the damper shall verify that there is no damper interference due to rusted, bent, misaligned, or damaged frame or blades.”



Periodic Testing Requirements

NFPA 105

Standard for the Installation of Smoke Door Assemblies and Other Opening Protectives

Maintenance

“All exposed moving parts of the damper shall be dry lubricated as required by the manufacturer.”

“If the damper is not operable, repairs shall begin without delay.”

“Following any repairs, the damper shall be test for operation in accordance with Section 6.5(Inspection and Testing).”

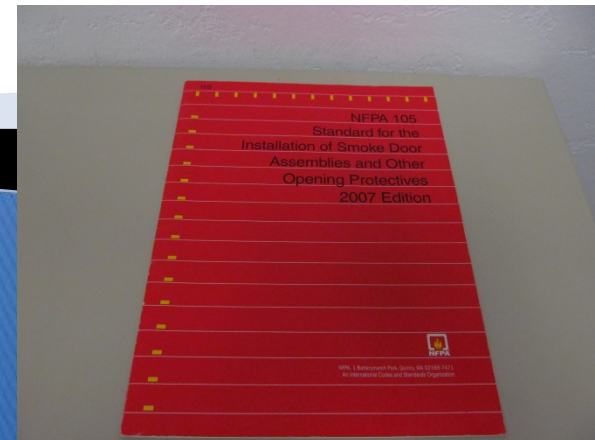

Periodic Testing Requirements

New AMCA Maintenance Guide



**Guide for Commissioning and
Periodic Performance Testing
of Fire, Smoke and Other Life
Safety Related Dampers**

Testing Options

▶ Position Switches

- providing positive blade indication

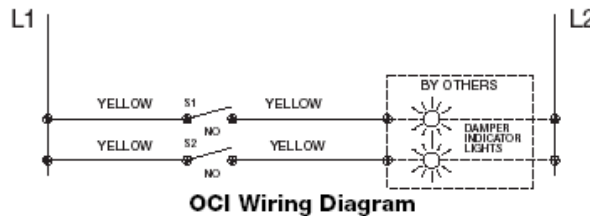

▶ Control Modules

- test the operation of damper from a remote location
- multiple configurations

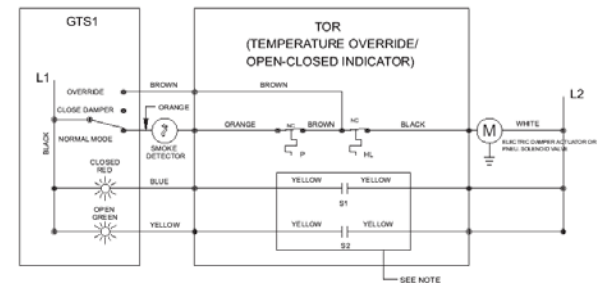

Testing Options

Test Stations



Test Switch



Toggle Switch

Keyed Switch

Momentary Switch

Lights Only

Installation Books

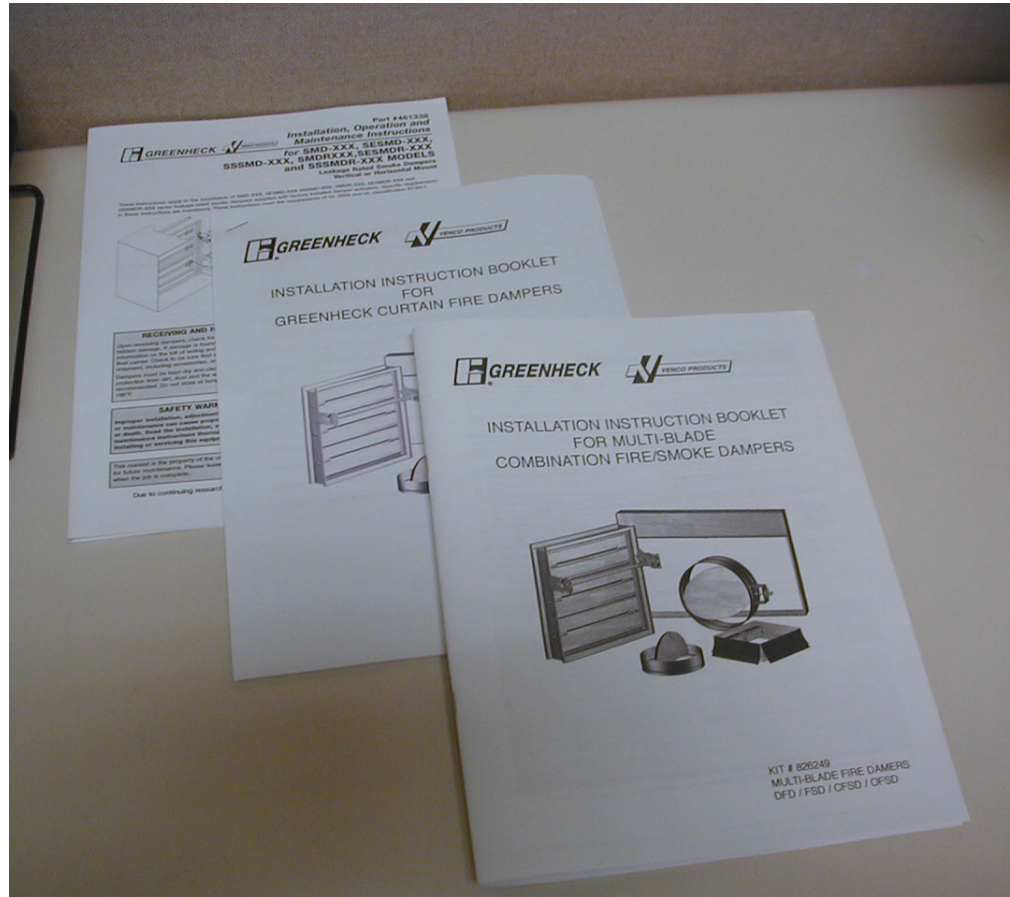

What if the barrier isn't rated?

- ▶ ~~Barrier~~
- ▶ Product
- ▶ Installation

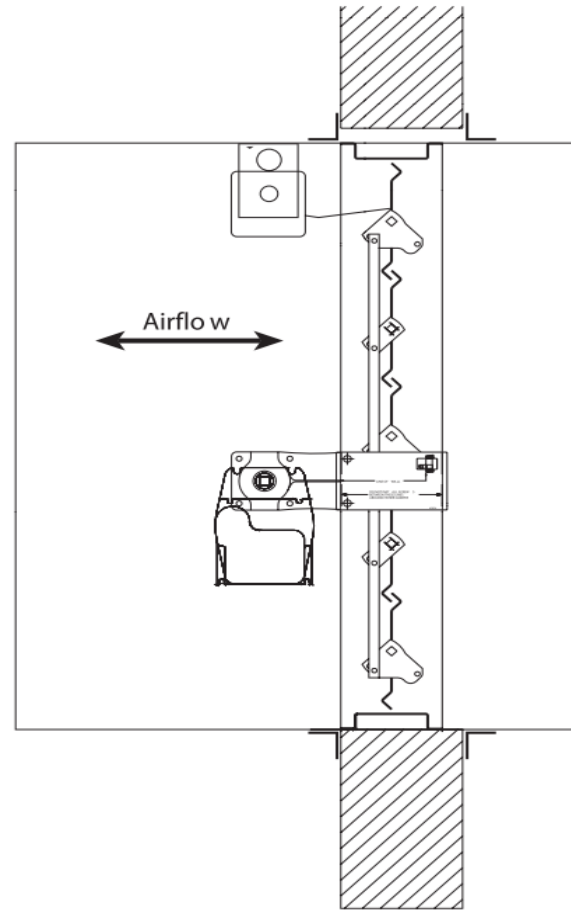

What if the barrier isn't rated?

- ▶ **Consult AHJ**
- ▶ **Determine impact on HVAC**
- ▶ **Determine go forward plan**
 - Leave and maintain
 - Abandon in place
 - Remove



Thank You

